

TEHNIČKI LIST

# MONTAŽNA PLOČICA SA PRIHVATNOM PODLOŠKOM 20/3

IT-KMP

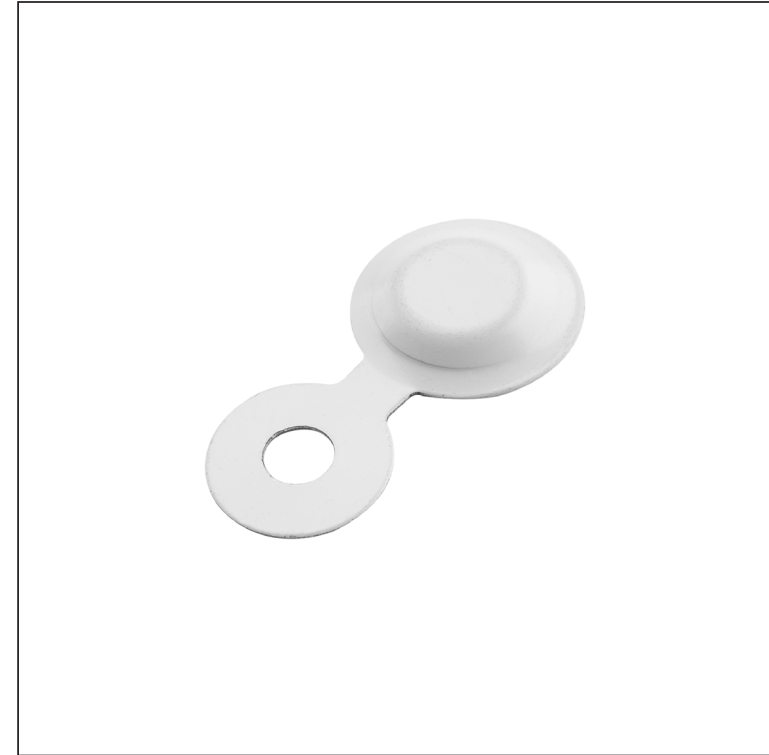
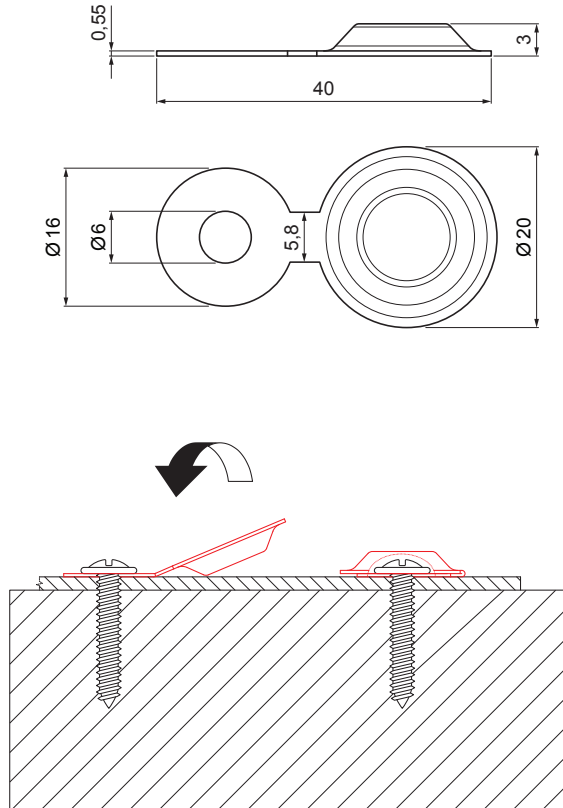

**B** Pocink obojeni – Bijela – RAL 9010

INDEX	ZAMJENA	DATUM	POTPIS			
VRSTA MATERIJALA			RAZRED OTPADA	TEŽINA kg	RAZMJER	
DIMENZIJA – POLUPROIZVOD						
POMOĆNA OPREMA				STN	OZNAKA ZA SORTIRANJE	
IZRADIO	Ing. Kluska M.			BILJEŠKA	REDNI BROJ POZICIJE	
TESTIRAO						
TEHNOLOG	TEHNOLOG			STARI NACRT	BROJ NACRTA	
NAZIV PROIZVODA	Montažna pločica sa prihvatnom podloškom 20/3			Broj stranica	IT-KMP	
				Stranica 		

Izrađeno: 21.04.2026 01:13:18

Podaci su podložni tehničkim promjenama