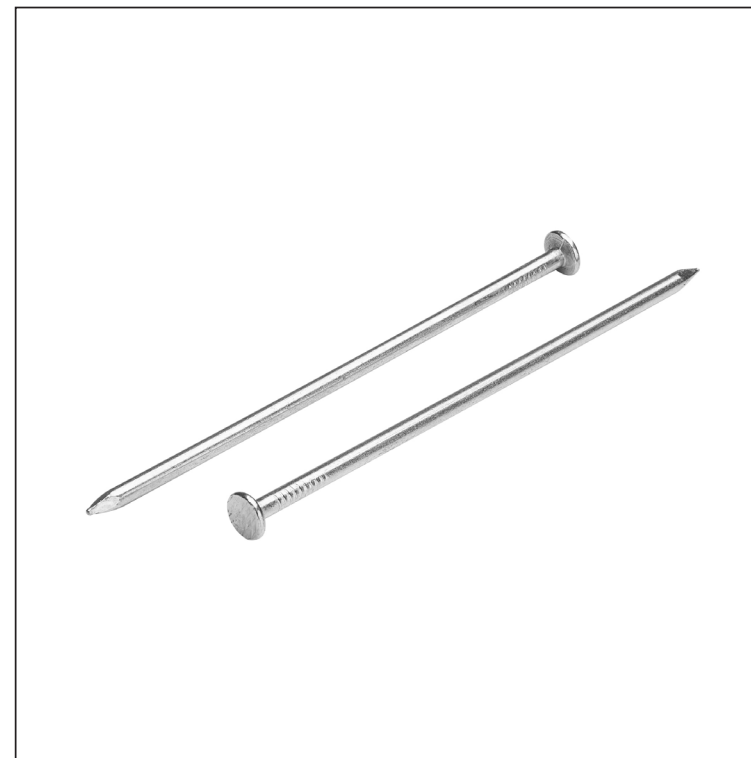
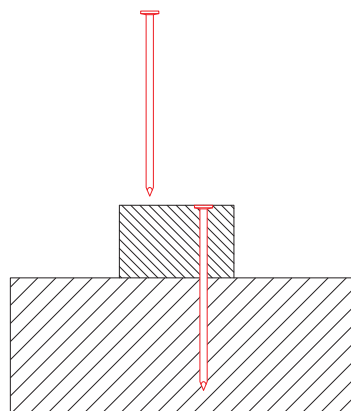
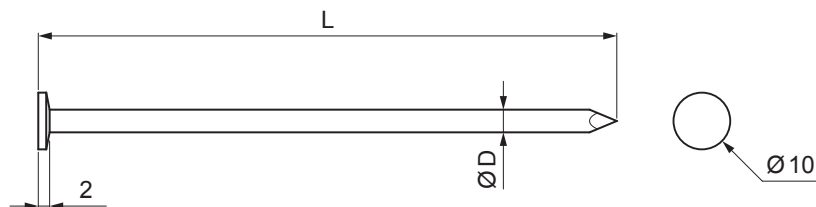

TEHNIČKI LIST

ČELIČNI GRAĐEVINSKI ČAVAO – GLAVA 10 mm

SM-OKCSS-H10

 Čelik

Dimenzije [mm]		
Nominalna veličina	Ø D	L
28/63	2,8	63
28/70	2,8	70
31/80	3,1	80
35/90	3,5	90
40/100	4,0	100
40/120	4,0	120
50/150	5,0	150
71/220	7,1	220
88/300	8,8	300

INDEX	ZAMJENA	DATUM	POTPIS	 QUALITY®	 Scan code for 3D model	
VRSTA MATERIJALA	DIMENZIJA – POLUPROIZVOD		TEŽINA kg			
POMOĆNA OPREMA			STN	OZNAKA ZA SORTIRANJE		
IZRADIO	Ing. Kluska M.	BILJEŠKA		REDNI BROJ POZICIJE		
TESTIRAO	TEHNOLOG		STARI NACRT	BROJ NACRTA		
NAZIV PROIZVODA	Čelični građevinski čavao – glava 10 mm			Broj stranica	SM-OKCSS-H10	Stranica 

Izrađeno: 06.06.2026 10:33:50

Podaci su podložni tehničkim promjenama