

TEHNIČKI LIST

ALUMIJSKA KALOTA ZA TRAPEZ TR 35

TR-ORK TR35

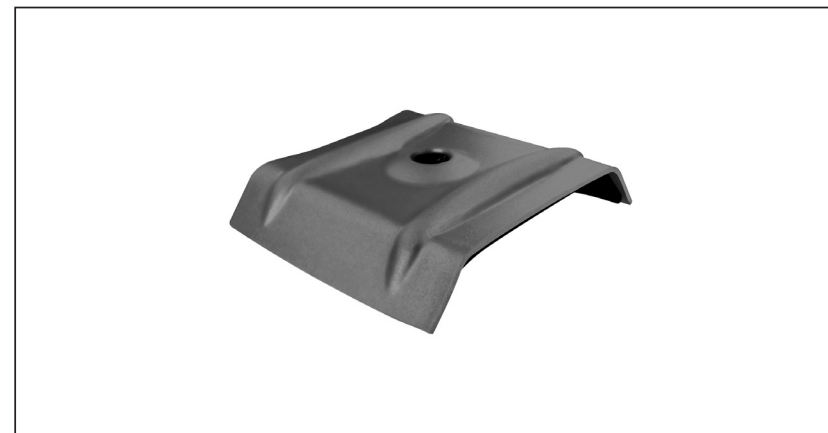
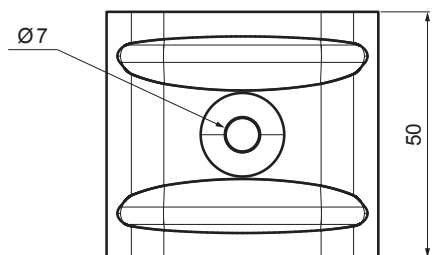
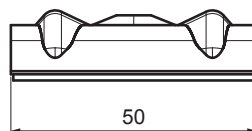
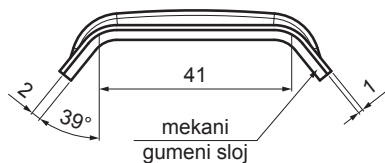

UPOTREBA:

- postaviti na TR u gornjem valu

OSOBINE:

- poboljšava stabilnost
- sigurnije pričvršćivanje

VRIJEDNOSTI ZA ODREĐIVANJE

ISPRAVNE KALOTE:

- širina gornjeg vala (mm)
- kut α (°)

ili

- širina gornjeg vala (mm)
- visina profila (mm)
- ukupna širina vala (mm)

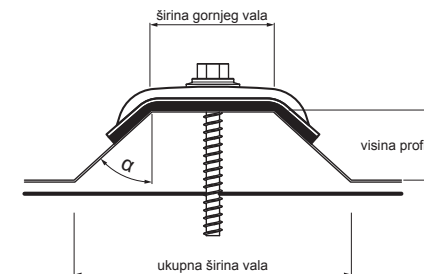

Aluminij obojeni – Antracit – RAL 7016

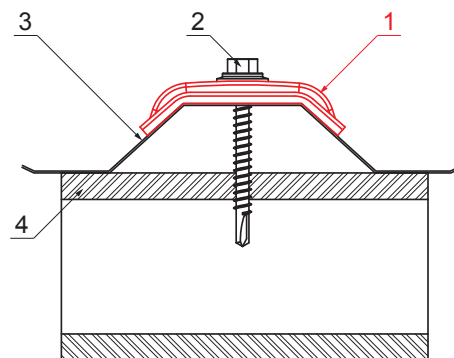
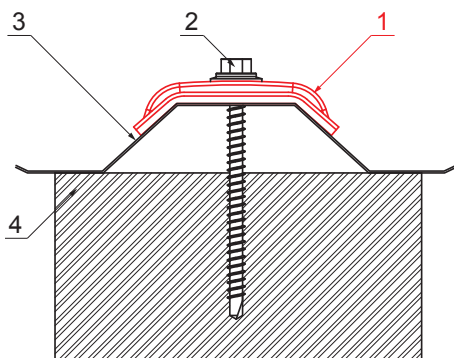

DETALJ:

1. alumijjska kalota za trapez
2. pocinčani TR vijak za drvo
3. krovni trapezni pokrov
4. drvo

DETALJ:

1. alumijjska kalota za trapez
2. pocinčani TR vijak za čelik
3. krovni trapezni pokrov
4. čelik

INDEX	ZAMJENA	DATUM	POTPIS		
VRSTA MATERIJALA	DIMENZIJA – POLUPROIZVOD		RAZRED OTPADA		
POMOĆNA OPREMA			STN		OZNAKA ZA SORTIRANJE
IZRADIO	Ing. Kluska M.	BILJEŠKA		REDNI BROJ POZICIJE	
TESTIRAO	TEHNOLOG		STARI NACRT	BROJ NACRTA	
NAZIV PROIZVODA	Alumijjska kalota za trapez TR 35			Broj stranica	Stranica

Izrađeno: 19.01.2026 16:42:09

Podaci su podložni tehničkim promjenama