

TEHNIČKI LIST

# EPDM GUMA ZA BRTVLJENJE SABIRNOG KOTLIĆA

# P-PKLZ T

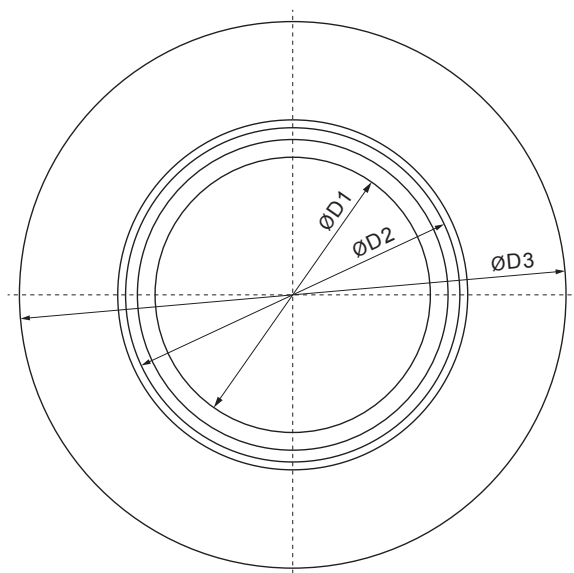
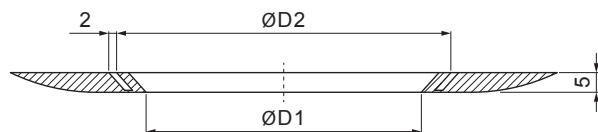

**IC** EPDM – Intenzivno crna – RAL 9005

Dimenzije [mm]			
Nominalna veličina	ØD1	ØD2	ØD3
70-85	70	85	140
100-110	90	95	140
110-125	100	120	169

INDEX	ZAMIJENA	DATUM	POTPIS			
VRSTA MATERIJALA	RAZRED OTPADKA	TEŽINA kg	RAZMJER			
DIMENZIJA – POLUPROIZVOD						
POMOĆNA OPREMA		STN			OZNAKA ZA SORTIRANJE	
IZRADIO	Ing. Kluska M.			BILJEŠKA	REDNI BROJ POZICIJE	
TESTIRAO						
TEHNOLOG	TEHNOLOG			STARI NACRT	BROJ NACRTA	
NAZIV PROIZVODA	EPDM guma za brtvljenje sabirnog kotlića			Broj stranica	P-PKLZ T	Stranica 

Izrađeno: 19.01.2026 16:42:16

Podaci su podložni tehničkim promjenama

TEHNIČKI LIST

# EPDM GUMA ZA BRTVLJENJE SABIRNOG KOTLIĆA

# P-PKLZ T

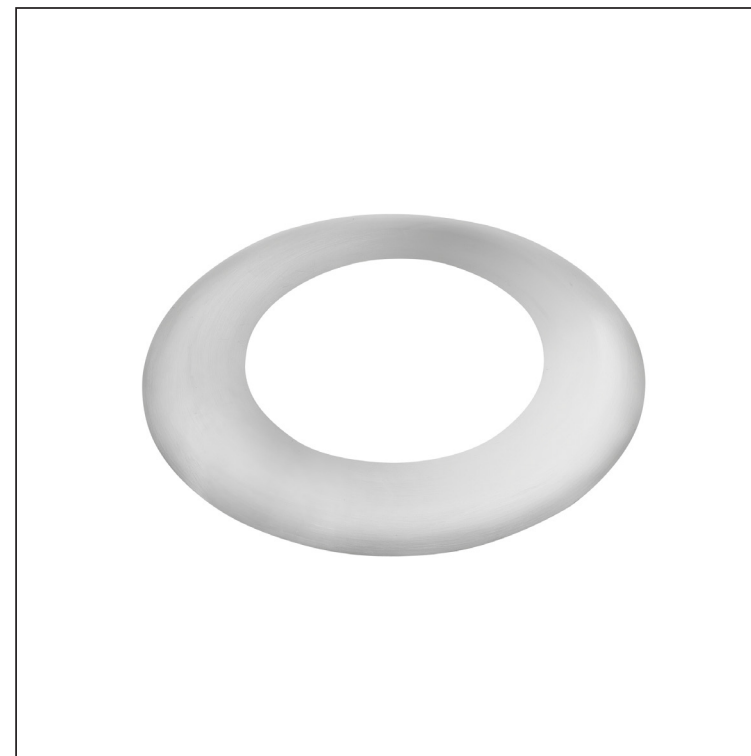
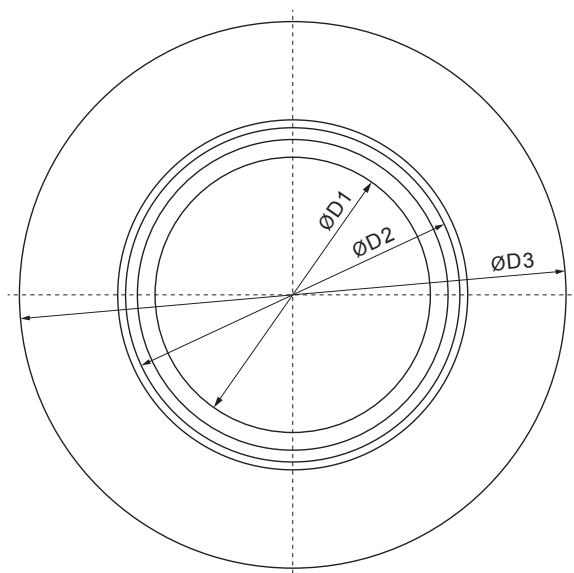
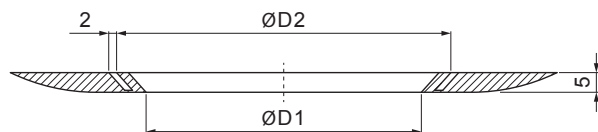

**PS** EPDM – Prašno siva – RAL 7037

Dimenzije [mm]			
Nominalna veličina	ØD1	ØD2	ØD3
70-85	70	85	140
100-110	90	95	140
110-125	100	120	169

INDEX	ZAMIJENA	DATUM	POTPIS			
VRSTA MATERIJALA	RAZRED OTRPADA	TEŽINA kg	RAZMJER			
DIMENZIJA – POLUPROIZVOD						
POMOĆNA OPREMA		STN			OZNAKA ZA SORTIRANJE	
IZRADIO	Ing. Kluska M.				BILJEŠKA	REDNI BROJ POZICIJE
TESTIRAO						
TEHNOLOG	TEHNOLOG			STARI NACRT		BROJ NACRTA
NAZIV PROIZVODA	EPDM guma za brtvljenje sabirnog kotlića			Broj stranica	P-PKLZ T 	

Izrađeno: 19.01.2026 16:42:16

Podaci su podložni tehničkim promjenama